

FMM-101 Monitor Module

Specifications

Nominal Operating Voltage:	15-32 VDC
Average Operating Current:	375µA maximum
EOL resistance:	47K Ohms
Maximum IDC wiring resistance:	1,500 Ohms
Temperature Range:	32° to 120° F (0° to 49° C)
Humidity:	10 to 93% noncondensing
Dimensions:	1.3" H x 2.75" W x 0.5" D
Wire length:	6" minimum

Before Installing

This information is included as a quick reference installation guide. Refer to the control panel installation manual for detailed system information. If the modules will be installed in an existing operational system, inform the operator and local authority that the system will be temporarily out of service. Disconnect power to the control panel before installing the modules.

NOTICE: This manual should be left with the owner/user of this equipment.

General Description

The FMM-101 monitor module can be installed in a single gang junction box directly behind the monitored unit. Its small size and light weight allow it to be installed without rigid mounting (see Figure 1). The FMM-101 is intended for use in intelligent, two-wire systems where the individual address of each module is selected using rotary switches. It provides a two-wire initiating device circuit for normally open contact fire alarm and security devices. This module can be used to replace an MMX-101 module in existing systems.

Compatibility Requirements

To ensure proper operation, this module shall be connected to a compatible Notifier system control panel (list available from Notifier).

Mounting and Wiring

NOTE: This module is intended to be wired and mounted without rigid connections inside a standard electrical box. All wiring must conform to applicable local codes, ordinances and regulations.

1. Connect the red (+) and black (-) wires to the positive and negative loop power leads of the signaling line circuit (SLC).
2. Connect the violet (+) and yellow (-) wires to a two-wire, normally open initiating loop.

3. Install the specified EOL resistor value to terminate the initiating loop.
4. Set the address on the module per job drawings.
Note: Some panels support extended addressing. In order to set the module above address 99 on compatible systems, carefully remove the stop on the upper rotary switch with thumb in the direction shown in Figure 1.
5. Install the module in the desired mounting location.

Figure 1. Removing rotary switch stop:

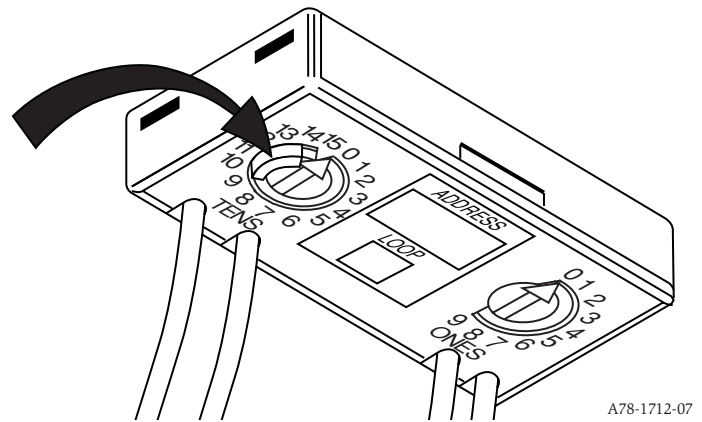

A78-1712-07

Figure 2. Typical 2-wire style B initiating device circuit configuration:

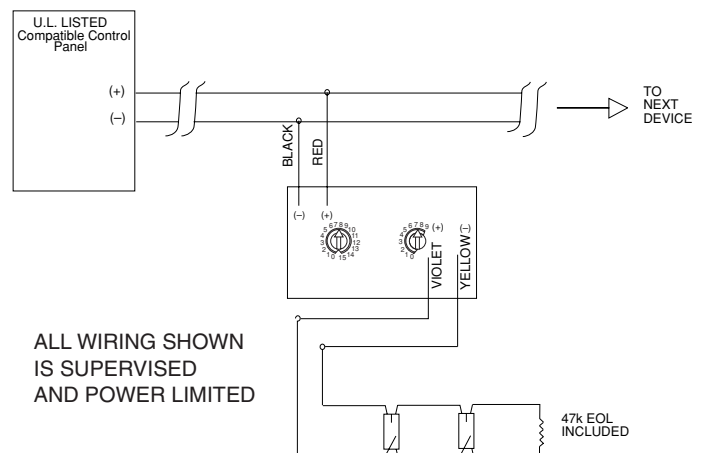

A78-1937-04